



Quick Draw

Rev 1.3

About Us

At Aces, we believe performance should be within reach for every car enthusiast. Born from a passion for hot rod technology, we push the boundaries of EFI innovation, empowering DIY builders and professionals alike. We do it “*For the People*” because we believe that achieving your dreams should never be exclusive.

Our commitment is simple: deliver exceptional products that inspire, at fair prices that make high-performance accessible. Whether it’s your first EFI setup or your latest build, we’re here to fuel your journey with precision, reliability, and cutting-edge technology.

We don’t just build EFI systems, we craft experiences that ignite passion, break barriers, and bring the joy of customization to everyone. Performance should never be out of reach, and with Aces, it never is. Our goal is to give our customers the absolute best value for their money both in the short and long run, so that they can look back and be proud that they bet on Aces.

Backed by over 10 years of experience, a history of winning results, and an unwavering dedication to research and development, Aces is built for performance, designed for dreamers, and made for those who refuse to settle.

Built for performance. Designed for dreamers. Made for you.

Table of Contents

QUICK DRAW™ TCM OVERVIEW	3
ADVANCED USER CAPABILITIES	3
WARNINGS, NOTES, AND NOTICES	4
1.0 Part List	4
2.0 QUICK DRAW™ TCM SYSTEM INSTALLATION	5
2.1 TCM Mounting	5
2.4 WIRING	5
3.0 WIRING HARNESS INSTALLATION	5
3.1 Main Power/Battery Connection	6
3.2 TCM Connectors	6
3.3 Harness Routing	7
4.0 HARNESS INSTALLATION AND SENSOR CONNECTIONS	7
4.11 Handheld	7
4.12 Can Splitter	7
4.13 LOOSE WIRES	7
4.14 ADDITIONAL OUTPUTS	8
5.0 TRANSMISSION HARNESS	8
5.1 Transmission Wiring	8
5.2 Transmission ECU Connector	9
5.3 Main Transmission Connector	9
5.4 Vehicle Speed Sensor (VSS)/Transmission Output Speed Sensor (OSS)	9
5.5 Turbine Speed Sensor (TSS)	9
5.6 Brake Switch (Brown)	9
6.0 QUICKSTART OF QUICK DRAW™ INSTRUCTIONS AND TUNING	9
6.1 INITIAL POWER-UP	9
6.2 HANDHELD NAVIGATION & USE	10
6.3 Connection	11
6.4 Navigation Buttons	12
6.5 Home Screen	12

7.0 CALIBRATION WIZARD 12

8.0 SENSOR VERIFICATION 15

QUICK DRAW™ TCM Tuning Reference Guide 15

QUICK DRAW™ TCM OVERVIEW

If your spot in the garage looks like an EPA Superfund site, and you're tired of turning 4000 RPM at 70mph, this product is for you! Burned transmission fluid in the morning doesn't smell like victory...it smells like time to ditch your obsolete, slipping slushbox and its cobbled-up kickdown linkage or troublesome throttle valve cable for a transmission that has been produced in the last 30 years! "Overdrive" should be more in your hotrod than just an old Bachman Turner cassette under your back seat, or a Post Malone song for you young whippersnappers.. Modern overdrive transmissions are cheap enough, but the cost of the average controller is more than a month of grocery trips, and the plasma bank says you're running dry...so what is an aspiring hot rodder in these times to do? Call ACES!!!

Most people agree that a modern overdrive transmission is a great addition to any hot rod, since it eliminates old kickdown linkages and throttle valve cables while improving fuel economy and durability... but what if your EFI system doesn't support it, or you are still running a carburetor? Stand alone controllers have been around for years, but they are pricey (easily over \$1000 with the proper harness), and may have compatibility issues. ACES now has a reasonably priced

option, the Quick Draw TCM transmission controller for popular GM electronic overdrive transmissions (4L60E, 4L65E, 4L80E, 4L85E), in a version for adding to ACES systems, as well as a stand-alone version that will work with carburetors and other EFI systems! Both use a 32-bit Power Architecture-based microcontroller (MCU) for speed, reliability, and error-resistance not found in most competing units. Since our system communicates with your ACES EFI through CAN bus technology, additional TPS sensors are not needed, and there are no issues with splitting the signal as with many other add-on systems. No additional programmers or displays are needed; just select the proper options on your existing ACES touchscreen! There is a simple calibration wizard that allows you to tune upshifts, downshifts, WOT shift points, line pressure (duty cycle) vs. gear, and torque converter lock up, without the use of a laptop.

If you have a carburetor, or a different EFI system, you can still use our stand-alone transmission controller. A 5" touch screen like the one in ACES EFI kits is included. Both systems come complete with the Quick Draw TCM module, a main harness, a transmission sub-harness, a CAN splitter cable, and additional wires needed for installation. The stand-alone systems also include a VSS extension harness. This system relies on a TPS signal that can be obtained from your existing EFI system, or from an aftermarket add-on TPS system for carbureted applications.

AcesEFI QUICK DRAW™ TCM Features

- 32-bit Power Architecture® based MCU and others IC drivers' chips for automotive powertrain applications

- Strong anti-interference, high stability hardware and software design

- Works with all Aces EFI system via CAN bus communication

- For carbureted applications, user must install a TPS sensor

- Transmission control is suitable for GM 4L60, 4L65, 4L80 or 4L85 transmissions.

- 5 inch High Resolution Full Color Touchscreen for Initial Setup, Tuning, and Gauge Displays

Simple Calibration Wizard - No laptop required.
 Tune Upshifts, Downshifts and WOT shift points
 Tune transmission line pressure (Duty cycle) vs gear
 Torque converter lockup programmable

ADVANCED USER CAPABILITIES

The ACES QUICK DRAW™ TCM software does allow for advanced tuning functionality. A laptop is required to access the advanced tuning functions. These functions are not recommended for enthusiasts without extensive TCM tuning knowledge and experience. Making changes to the calibration in the advanced tuning functions can lead to catastrophic engine damage if not done correctly. ACES is not responsible for any damage caused due to advanced tuning errors.

Thank you for betting on ACES! We are proud to be your manufacturer of choice.

1.0 Part List

Item	Description	QTY	Service Part
1	QUICK DRAW™ ECU	1	AS2020
2	Handheld	1	AS2009(Stand alone kit)
3	Main harness	1	AH2020A/AH2020-1
4	Transmission sub harness	1	AH2011-2
5	VSS extension harness	1	AH2020-2 (Stand alone kit)
6	Additional wires	1	AH2020-3
7	Aces CAN splitter cable	q	AH2020-4

2.0 QUICK DRAW™ TCM SYSTEM INSTALLATION

2.1 TCM Mounting

The TCM can be mounted inside the passenger compartment (preferable location) or in the engine compartment. If mounted in the engine compartment, follow these guidelines:

The TCM should be located such that water or road debris aren't directly hitting it.

It should also be located such that it isn't extremely close to exhaust manifolds or headers.

It should be mounted such that it is as far away from spark plug wires, CD ignition boxes, or other "electrically noisy" devices as is reasonably possible.

Make sure the connector end of the TCM is pointed DOWN such that water cannot make its way into the ECU terminals. Do not over-tighten mounting hardware if the TCM is not mounted on a flat surface.

2.4 WIRING

This section overviews how to properly install the wiring harnesses for this system.

An TCM system depends heavily on being supplied with a clean and constant voltage source. The grounds of an electrical system are just as important as the power side.

QUICK DRAW™ TCM's contain multiple processing devices that require clean power and ground sources. The wiring harnesses for them must be installed in such a manner that they are separated from “dirty” power and ground sources.

- Install the main power and ground directly to the battery POSTS/TERMINALS, not to any other place!

Keep sensor wiring away from high voltage or “noisy/dirty” components and wiring, especially secondary ignition wiring (plug wires), ignition boxes, and associated wiring. It is best that the plug wires do not physically contact any TCM wires.

- Properly crimp or crimp and solder any wire connections. Apply quality heat shrink over any of these connections.

- It is critical that the engine has a proper ground connection to the battery and chassis.

NEVER run high-voltage or “noisy/dirty” wires in parallel (bundle/loom together) with any TCM sensor wiring. If wires need to cross, try to do so at an angle.

- Do not use the electric fan outputs to directly power a fan. They must Ground trigger a relay.

- Do not use improper crimping tools.

- Do not use things like “t-taps”, etc. Use proper crimpers/solder and heat shrink.

- It is never recommended to splice/share signal wires (such as TPS, etc.) between different electronic control units (i.e., “piggyback”).

- Do not connect the red/white switched +12V wire to “dirty” sources, such as the ignition coil, audio systems, or 12V sources connected to HID headlamps.

3.0 WIRING HARNESS INSTALLATION

3.1 Main Power/Battery Connection

The QUICK DRAW™ TCM has a main battery power connector labeled 12V Battery + (red) and ground connector labeled 12V battery - (black) on the Main harness. The loose wires of the QUICK DRAW™ harness located approximately 20” from the TCM connectors are the power (red wire) and ground (black wire), which should be connected DIRECTLY to the positive and negative battery terminals. If you have a “dual post” battery, it is a great idea to purchase separate posts/studs to connect the TCM power and ground to the non-used terminals. Only use the fused power cable with the proper connectors supplied by ACES. Do not connect to the TCM until after ALL wiring and installation is performed.

3.2 TCM Connectors



QUICK DRAW™ TCM has one 34 pin connector:

PIN	Definition		PIN	Definition	
1	AGND		18	CAL_SCL	
2	S5V		19	-	
3	RangeA		20	-	
4	RangeB		21	SOL_A	
5	RangeC		22	SOL_B	
6	ATF		23	TCC_SOLENOID	
7	CANH		24	LINE PRESSURE	
8	IGNSW		25	TCC_CONTROL	
9	Brake_SW		26	VMAIN	
10	TCC_LOCK		27	Bump_up	
11	MODE_SCL		28	GND	
12	TPS		29	Bump_down	
13	-		30	Turbine_speed	
14	VSS		31	3-2 SOLENOID	
15	CANL		32	REV_OUT1	
16	TCC_UNLCK		33	TACH_OUT	
17	TACH_IN		34	MRD	

3.3 Harness Routing

If the TCM is mounted in the interior, the main harness will have to be routed through the firewall into the engine compartment. Use a 2" hole saw to create a hole in a desired location if no other point of access is available. Use a grommet for a 2" hole to seal this area.

If the TCM is mounted in the engine compartment, the cable to the 5" handheld will have to be routed to the CAN connector on the main harness (located near the TCM main connector). This is assuming you want to access the hand-held module after startup. This will require routing the small CAN connector somewhere through the firewall.

4.0 HARNESS INSTALLATION AND SENSOR CONNECTIONS

The following indicates the primary sensors that are required to be connected. Each connector on the main harness is labeled with the sensor name. The name on this label for each sensor is in parenthesis below.

4.11 Handheld

The handheld controller is used to create the initial calibration for the system, allows for simple tuning changes during regular operation, and is also used to view various real-time data of the TCM system. It should be installed such that the handheld controller can be easily used in the passenger compartment. The handheld plugs directly into the main harness at either connector labeled **"CAN."** This connector is located approximately 12" from the ECU connector. The handheld does not have to remain in the vehicle or be utilized after the vehicle is set up and running properly.

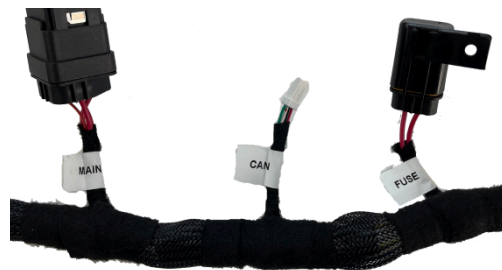

CAN Bus connector

4.12 CAN Splitter

Aces EFI CAN splitters enable you to add an or more additional CAN devices to your Aces EFI systems, without the need to unplug the handheld. This easy-to-install wiring harness simply plugs into the CAN connector on your main harness—then lets you plug in any Aces EFI CAN device, such as a digital dash or USB to the CAN communication cable. Boost the versatility of your fuel injection wiring with Aces splitters.

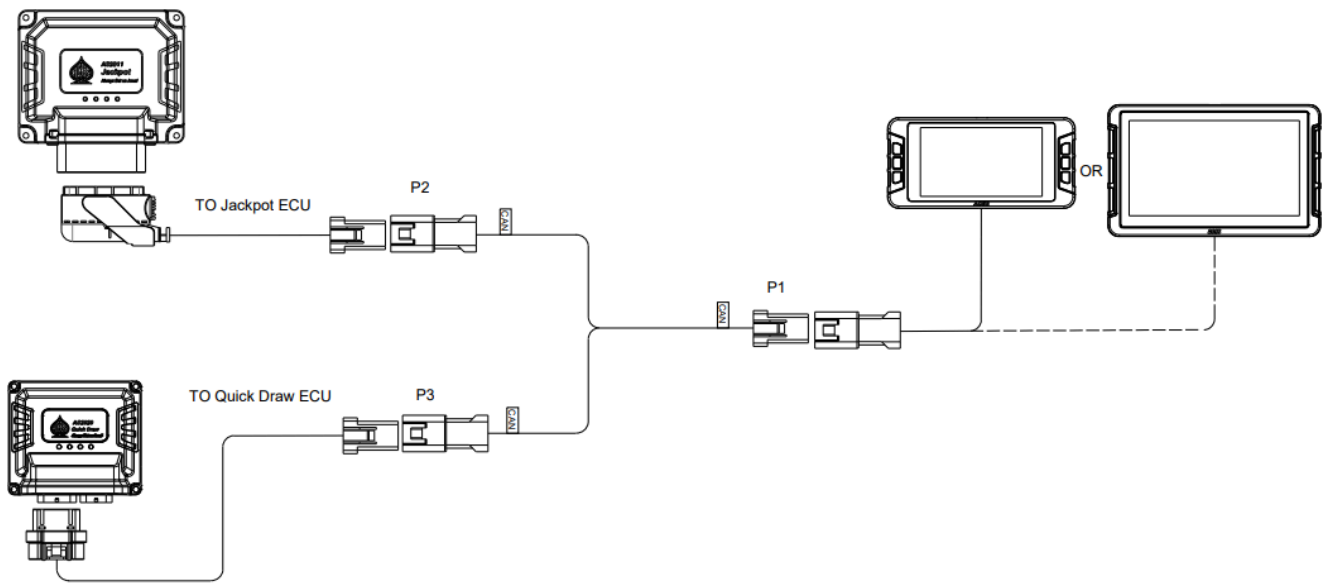

4.13 LOOSE WIRES

The following loose wires in the main wiring harness should be connected as follows on all systems.

IGNSW (Red) Should be connected to a clean key-on/cranking +12V power source. Power source should only be active when the ignition is on (key-on power). Make sure the source has power when the engine is cranking as well (check with voltmeter). Not all sources apply power when the ignition switch is in “cranking” position. This wire is located approximately 20” from the ECU connectors. DO NOT connect to a “DIRTY” source like an ignition coil!

12V Battery + (Red) MUST be connected directly to the positive battery terminal. This powers the fuel pump and fuel injectors. This wire is protected by a fuse in a sealed fuse holder. The fuse holder is located about 8" from the TCM connector. A 20-amp (20A) fuse is pre-installed.

12V Battery - (Black) MUST be connected directly to the negative battery terminal. Using a traditional chassis ground can cause electrical issues with the QUICK DRAW™ TCM. This wire is located approximately 20” from the TCM connectors.

4.14 ADDITIONAL OUTPUTS

Bump_down (Green) Once in manual mode, momentary switch to ground to downshift.

Bump_up (Purple) Once in manual mode, momentary switch to ground to up shift.

SPEED_OUT (White) VSS output

REV_OUT1(Green) Optional - Programmable ground output

CAL_SCL (Brown) The QUICK DRAW™ TCM supports two calibration modes. Calibration A is enabled by default and can be considered a street or daily driven calibration. Calibration B can be used for racing, off road, or aggressive shifting settings. When the brown wire is grounded, Calibration B is enabled.

Tach_IN (Gray) A tach output from a sensor or module. This is the tach input for the TCM.

TCC_UNLCK ((Purple) (+12V) Switch to 12v to unlock Torque Converter Clutch. Normally connected to the brake pedal switch to unlock TCC when brakes are applied.

Note: This function will prevent the TCC from locking under any operating condition while activated with 12v.

TCC_LOCK (Yellow) Switch to ground to lock Torque Converter Clutch in 2nd-4th gear regardless of vehicle speed.

Brake_SW (Blue) This can be installed to a +12v source. This input is used to unlock the torque converter.

5.0 TRANSMISSION HARNESS

5.1 Transmission Wiring

The transmission harness can be used on GM 4L60E, 4L65E, 4L80E, and 4L85E transmissions. Each connector is labeled.



Transmission Harness

5.2 Transmission ECU Connector (B1)– Plugs into the C4 connector on the QUICK DRAW™ main wire harness AH2020. Plugs into the last connector opposite the main harness.

5.3 Main Transmission Connector – Plugs into the connector on the transmission on the driver’s side of 4L80E (installed horizontally) and the passenger side of 4L60E (installed vertically).

5.4 Vehicle Speed Sensor (VSS)/Transmission Output Speed Sensor (OSS) – Located on the rear driver’s side on a 4L80E and the rear passengers’ side on a 4L60E

5.5 Turbine Speed Sensor (TSS) – The 4L60E does not have a turbine speed sensor. For 4L80E applications, it is located towards the front driver’s side of the transmission. NOTE: the 4L70E has an internally wired TSS, but it does not connect to the QUICK DRAW™ harness. The TSS is not used for calibration in the ECU, just for monitoring purposes.

5.6 Brake Switch (Brown) – Wired to the brake light switch. This must be installed to a +12v source (as most brake light switches are). This input is used to unlock the torque converter when the brakes are applied.

6.0 QUICKSTART OF QUICK DRAW™ INSTRUCTIONS AND TUNING

The QUICK DRAW™ TCM systems are designed to be easy to use for the first time TCM tuner. The instructions are set up in that manner as well. These instructions will not go into detail about TCM theory and operation. They will provide the steps necessary to get you up and running quickly. The QUICK DRAW™ TCM system allows for the user to perform some basic changes to the tuning if they desire to do so.

The instructions are sequenced to get you up and running so you can enjoy your vehicle, then review some of the parameters that can be adjusted to fine tune your vehicle later, if desired.

6.1 INITIAL POWER-UP

Turn the ignition key to the “run” position. This should apply power to the TCM, as well as to the ACES Handheld control module. The handheld should power up and the Home Screen should appear.

The Home screen contains icons which will navigate to different functional features of the 5” Touch Screen. These features will be discussed in detail throughout this manual.

6.2 HANDHELD NAVIGATION & USE

The handheld is composed of a 5.0" capacitive touch screen with six physical buttons. The handheld is equipped with a robust color LCD display with a large screen size. There are navigation buttons on either side of the screen. The external interface is CAN bus- and USB-C-based. All operations can be done by touching the screen or the physical buttons on either side.

The handheld can be used to calibrate the system and to monitor engine data (engine RPM, AFR targets, battery voltage, etc.) when it is connected to the TCM. It is very portable and can be connected to TCM for monitoring and calibration at any time.

There are buttons on either side of the display, which activate different functions and operations within the system. The user can operate the scan tool by touching the screen or the buttons on either side, such as switching the interface and modifying the calibration data, upload/download calibration data, etc.

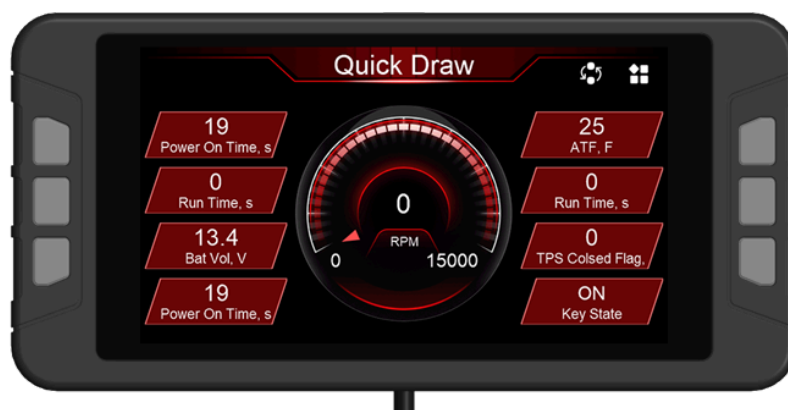

Making Adjustments

(1) Slider Bar: Slide the bar or click "◀" and "▶" on the touchscreen to adjust the parameters, click "💾" to save,

and click "↶" to cancel saving



(2) Numeric keyboard: Click the edit box "100.0%" above the sliding bar to pop up the numeric keyboard.



(3) 2D Graph: Drag the red dot on the graph or click the mechanical buttons on both sides to adjust the parameters. When adjusting the parameter, the y-axis coordinate value of the currently adjusted parameter will be displayed in the upper right corner. The four buttons on both sides of the interface will disappear after a short display. Clicking the two mechanical buttons at the lower left corner can switch the position of the green dot, clicking the button at the right center can raise the position of the green dot, and clicking the mechanical button at the lower right corner can lower the position of the yellow dot. The y-axis coordinate value of the green dot is displayed in the upper right corner of the interface.

After the configuration is complete, click "📁" to download the calibration data to the ECU; click "↶" to cancel the modification.

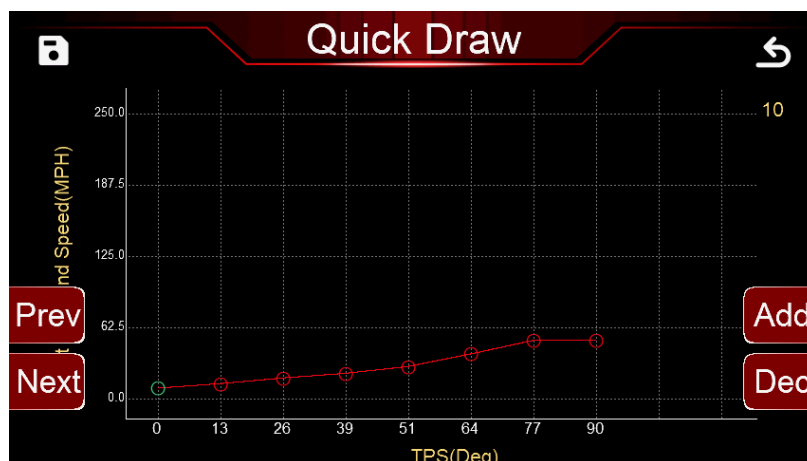

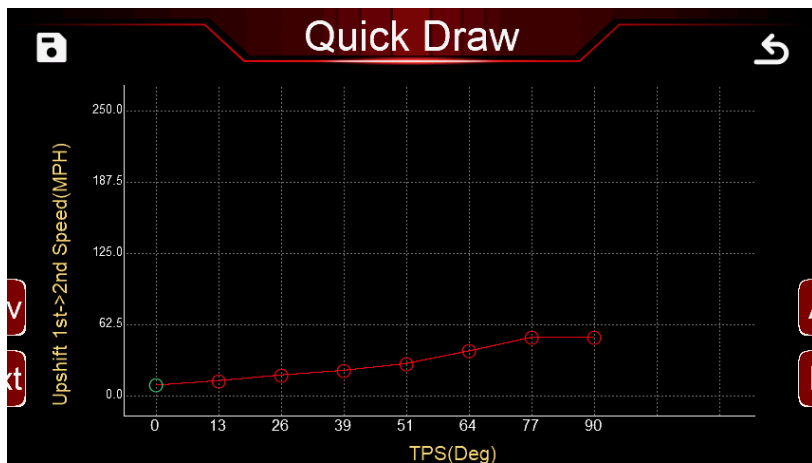

6.3 Connection

The handheld connects to the TCM through the CAN bus connection, and its software can be updated through the Type-C USB interface when needed.

6.4 Navigation Buttons

ACES designed its handheld controller for reliable operation and easy use. There are buttons on either side of the display, which operate different interfaces within the system. The user can operate the scan tool by touching the screen or the buttons, such as switching the interface and modifying the calibration data, upload/download calibration data, etc.

6.5 Home Screen



The home screen has 6 icons that direct the user to different functions.

Monitor - A variety of gauge and dash displays.

Calibration - Allows for various parameters to be easily adjusted.

Logging - The user can freely choose the monitored object to write to the log file in order to better observe the TCM data.



File - Saves and loads calibrations. Also shows information about the TCM and handheld controller.



Setting - The local settings can adjust the backlight brightness, sound volume of button or touch, and information about the handheld.

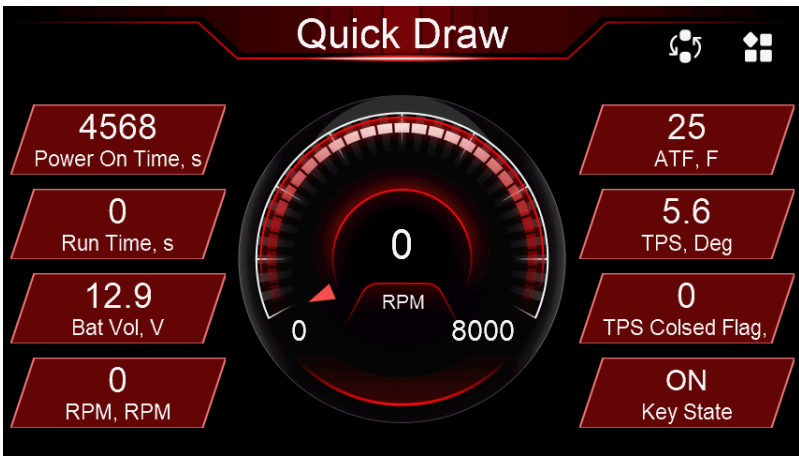

Wizards - Creates a base calibration and performs the TPS Zero Auto learn function.

The QUICK DRAW™ TCM system will build a custom calibration for your engine based on a few easy-to-answer questions. To begin, Choose the “Wizards” icon from the main menu.

7.0 CALIBRATION WIZARD

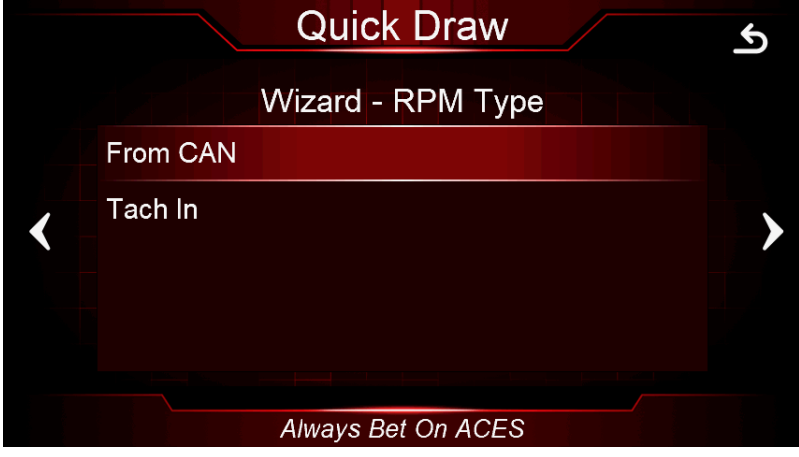
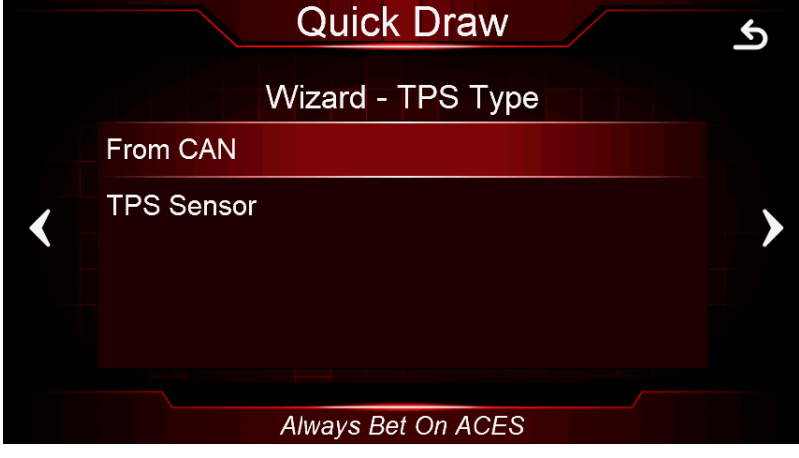
	<p>Select System</p> <p>Connect the Handheld to the wire harness and Power up the TCM. Select QUICK DRAW™.</p>
	<p>Home Screen</p> <p>Click the "☰" icon in the upper right corner to enter the Main Menu.</p>
	<p>Main Menu</p> <p>Click Wizards from the main menu.</p>

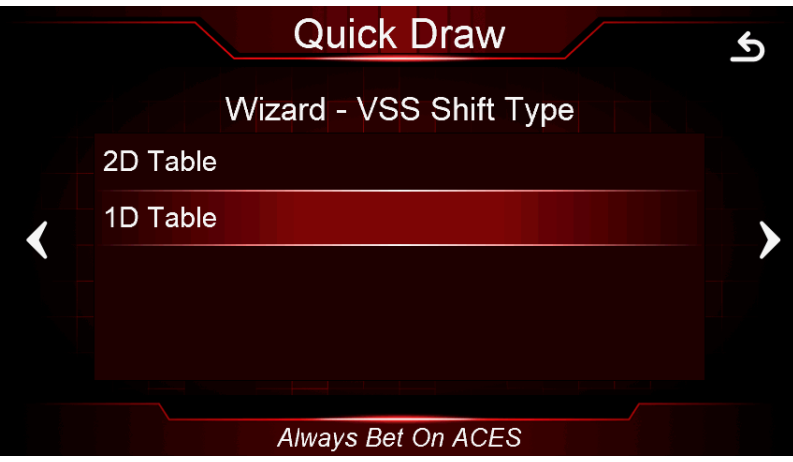
 <p>Quick Draw</p> <p>Start Wizard TPS Autaset</p> <p>Always Bet On ACES</p>	<p>Wizards</p> <p>Click Start Wizard to configure your Quick Draw™ TCM system.</p> <p>If you use a remote TPS sensor, after complete your Wizard, you have to do TPS Autaset.</p>
 <p>Quick Draw</p> <p>Wizard - Transmission Type</p> <p>GM 4L60 (1.75 2nd Gear)</p> <p>GM 4L60 (1.63 2nd Gear)</p> <p>GM 4L80/5E</p> <p>Always Bet On ACES</p>	<p>Transmission Type</p> <p>Select your trans type</p>
 <p>Quick Draw</p> <p>Wizard - RPM Type</p> <p>From CAN</p> <p>Tach In</p> <p>Always Bet On ACES</p>	<p>RPM Type</p> <p>>When you have Aces EFI system, Quick Draw will Works via CAN bus communication, you have to select From CAN</p> <p>>If you have a carburetor, or a different EFI system, you have to select Tach In</p>
 <p>Quick Draw</p> <p>Wizard - TPS Type</p> <p>From CAN</p> <p>TPS Sensor</p> <p>Always Bet On ACES</p>	<p>TPS Type</p> <p>>When you have Aces EFI system, Quick Draw will Works via CAN bus communication, you have to select From CAN</p> <p>>If you have a carburetor, or a different EFI system, you have to select Tach In</p>

	<p style="text-align: center;">VSS Shift Type</p> <p>1D Table, You can use 5" handheld or 7"Pro to tune your shift points,</p> <p>2D Table, you can use Aces PC tuning software to tune by CAN cable.</p>
	<p style="text-align: center;">Cylinder Select</p> <p>Cylinder select is for RPM calculation</p>
	<p>Click " ✓ " to save the configuration to the ECU. Click " ⏪ " to return to the wizard to modify configuration. Or click " ⏩ " to return to the main menu.</p>

8.0 SENSOR VERIFICATION

Before starting the vehicle, verify that every sensor is reading properly. Turn the key off and cycle it back on.

On the Home Screen, With the key on and the engine off, these sensors should read as follows:

Engine RPM – Will show “0” when not cranking.

MAP (Manifold Air Pressure) – Should read between 95-102. At high elevations it could read as low as 75.

TPS (Throttle Position Sensor) – Slowly depress the throttle to wide open. It should read 100 at wide open throttle. Cable operated throttle bodies should read 0 closed.

CTS (Coolant Temperature Sensor) – reads engine temperature. If the engine is “cold,” it should read close to ambient temperature.

Battery – Will read battery voltage. It should be 12.0 volts minimum.

NOTE: If ANY of these sensors are not reading properly DO NOT attempt to start the engine.

QUICK DRAW™ TCM Tuning Reference Guide

The QUICK DRAW™

TCM system allows users to adjust some basic tuning settings to optimize engine performance. Tuning is split up into “**Basic**” and “**Advanced.**”

Basic Tuning allows for changes to the basic calibration data for **Sensors**, and **Gear setting**. Advanced Tuning is a control function and 2D table that are less commonly used. These parameters require some understanding before changing.

The Main Menu has six options: Monitor, Tuning, Logging, Files, Settings, and Wizards.

Click the "" icon in the upper right corner to return to the Home Screen.



1.Sensors



1. TPS Coef

The filter of TPS signal

2. TPS Closed Threshold

This number is the threshold of TPS closed. if it is less than or equal to this value, TPS is considered to be closed.

3. TPS Closed Hys

This number is the hysteresis during TPS closed, bigger than Closed threshold. and the hysteresis value to avoid frequent changes of TPS between the closed and open states.

4. TPS Default Zero

The AD count of TPS closed, TPS default zero point. When the TPS signal fails or TPS zero point learning error occurs, the system will use this default value as TPS zero point.

5. TPS Zero Window Size

The window range allowed for TPS zero-point (Closed) learning

6. TPS Calc Max

AD value when all TPS are fully open.

7. TPS Calc Min

AD value when TPS is closed

2. Gear Setting

2.1 Basic Gear Setting Parameters

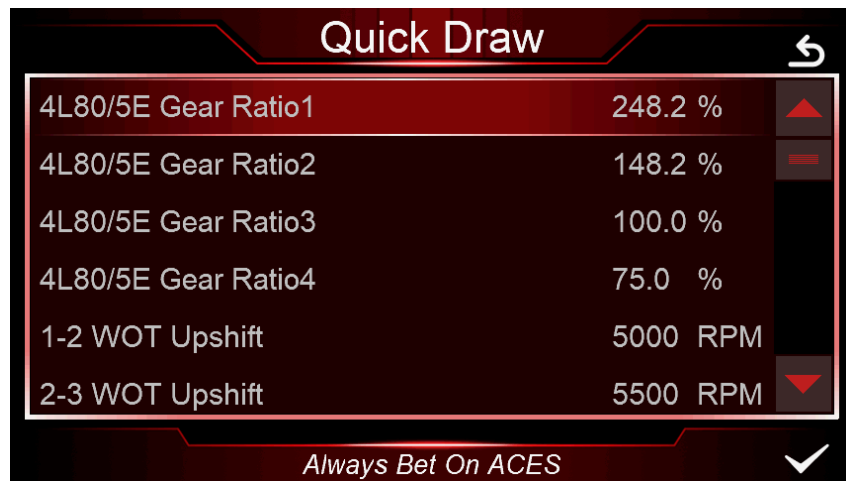

4L80/5E Gear Ratio1

4L80/5E Gear Ratio2

4L80/5E Gear Ratio3

4L80/5E Gear Ratio4

The gear ratio of your 4L80/5E transmission.

WOT shift

1-2 WOT Upshift

This is the RPM at which the 1 -2 upshift will occur.

2-3 WOT Upshift

This is the RPM at which the 1 -2 upshift will occur.

3-4 WOT Upshift

This is the RPM at which the 1 -2 upshift will occur.

4L60/5E Gear Ratio1

4L60/5E Gear Ratio2

4L60/5E Gear Ratio3

4L60/5E Gear Ratio4

The gear ratio of your 4L60/5E transmission.

Tire Diameter

The overall tire diameter. Example (234/65R15 tire size =27" tire diameter)

Rear Gear Ratio

The final drive axle ratio of your car. Example (3:73, 4:10, 3:23)

Teeth For VSS Sensor

The teeth number of VSS sensor for calculation

VSS Correction

The Correction of vehicle speed, use a GPS instrument or Google Map on a smartphone, or other calibrated measurements to set this correctly.

2.2 Advanced Gear Setting Parameters

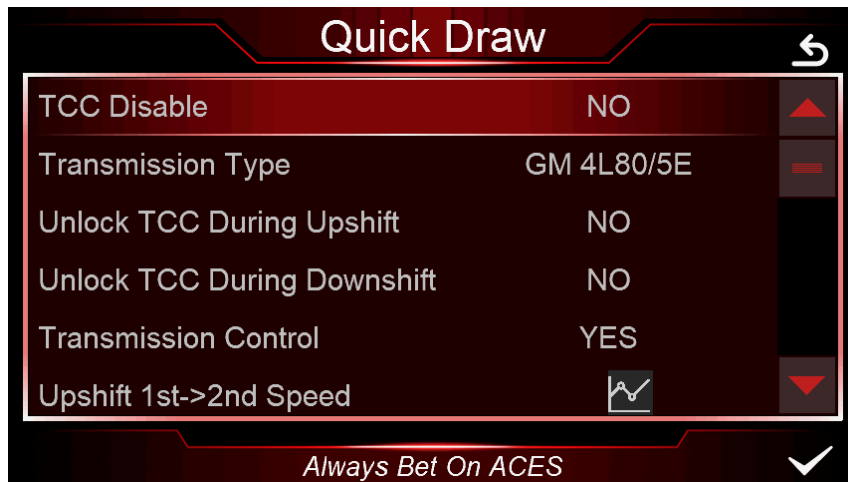

TCC Disable

This will disable TCC functionality in all conditions.

Transmission Type

Select your transmission type: 4L60/65E or 4L80/85E

Unlock TCC During Upshift

This parameter only comes into play if the converter is locked in multiple gears . If enabled the converter will unlock when an upshift is commanded then relock.

Unlock TCC During Downshift

This parameter only comes into play if the converter is locked in multiple gears . If enabled the converter will unlock when a downshift is commanded then relock.

Transmission Control

Transmission control enable or disable, chosen by YES or NO

Upshift 1st->2nd Speed

Table used to modify 1-2 upshifts based on throttle position (or MAP for boosted applications) and speed.

Upshift 2nd->3rd Speed

Table used to modify 2-3 upshifts based on throttle position (or MAP for boosted applications) and speed.

Upshift 3rd->4th Speed

Table used to modify 3-4 upshifts based on throttle position (or MAP for boosted applications) and speed.

Downshift 2nd->1st Speed

Table used to modify 1-2 downshift based on throttle position (or MAP for boosted applications) and speed.

Downshift 3rd->2nd Speed

Table used to modify 3-2 downshift based on throttle position (or MAP for boosted applications) and speed.

Downshift 4th->3rd Speed

Table used to modify 4-3 downshift based on throttle position (or MAP for boosted applications) and speed.

Quick Draw stand alone kit harness AH2020A

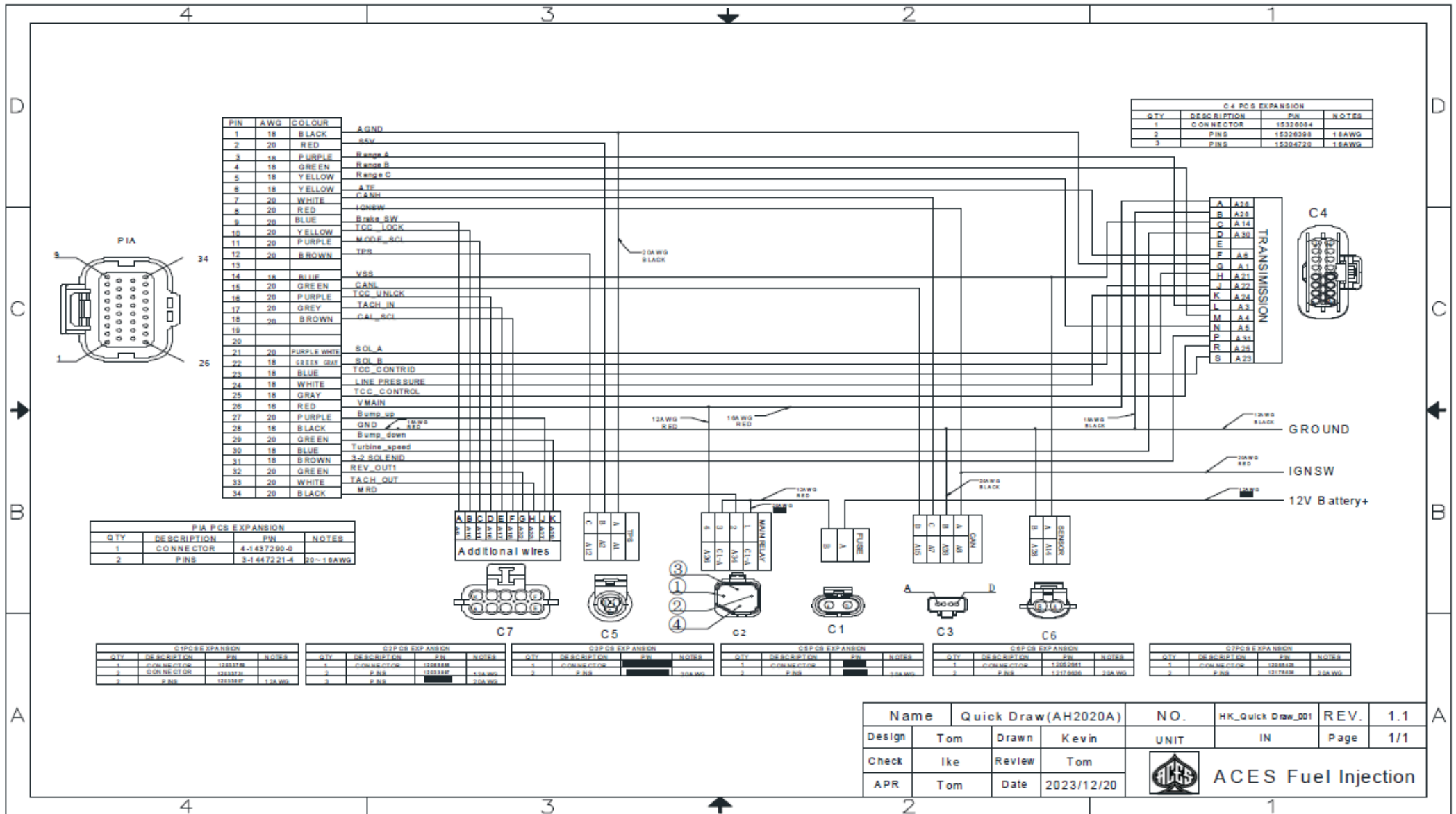

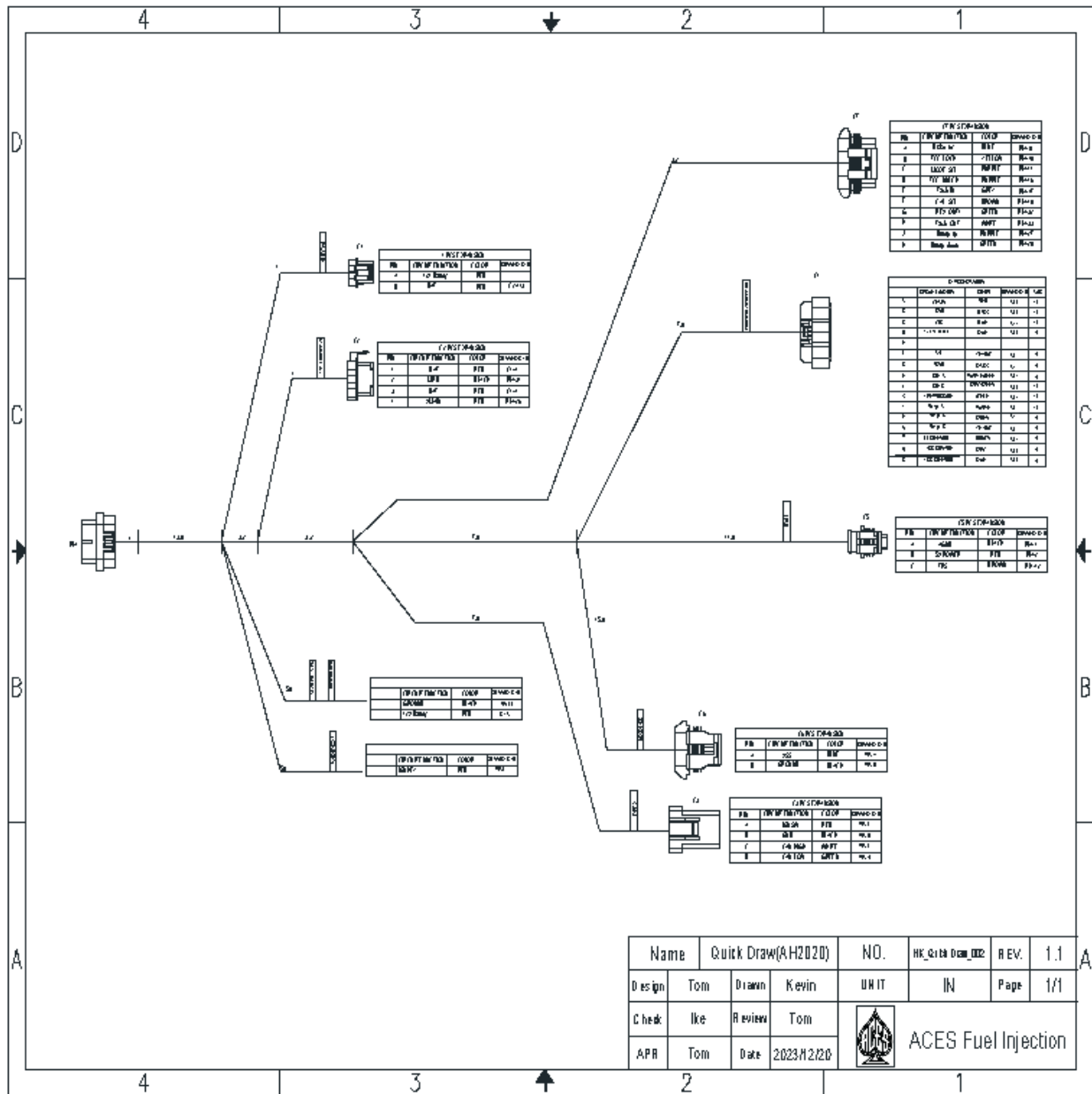

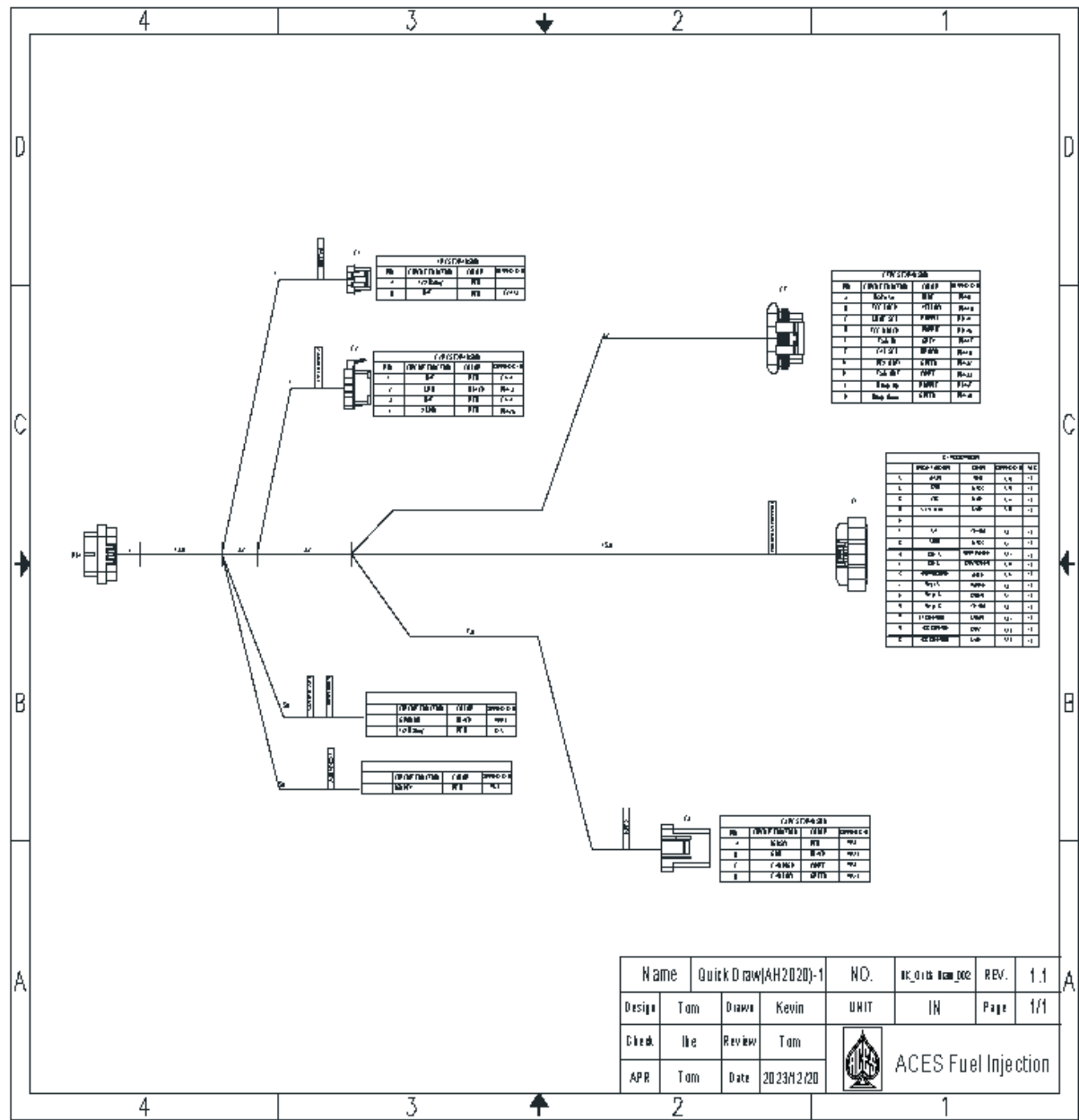

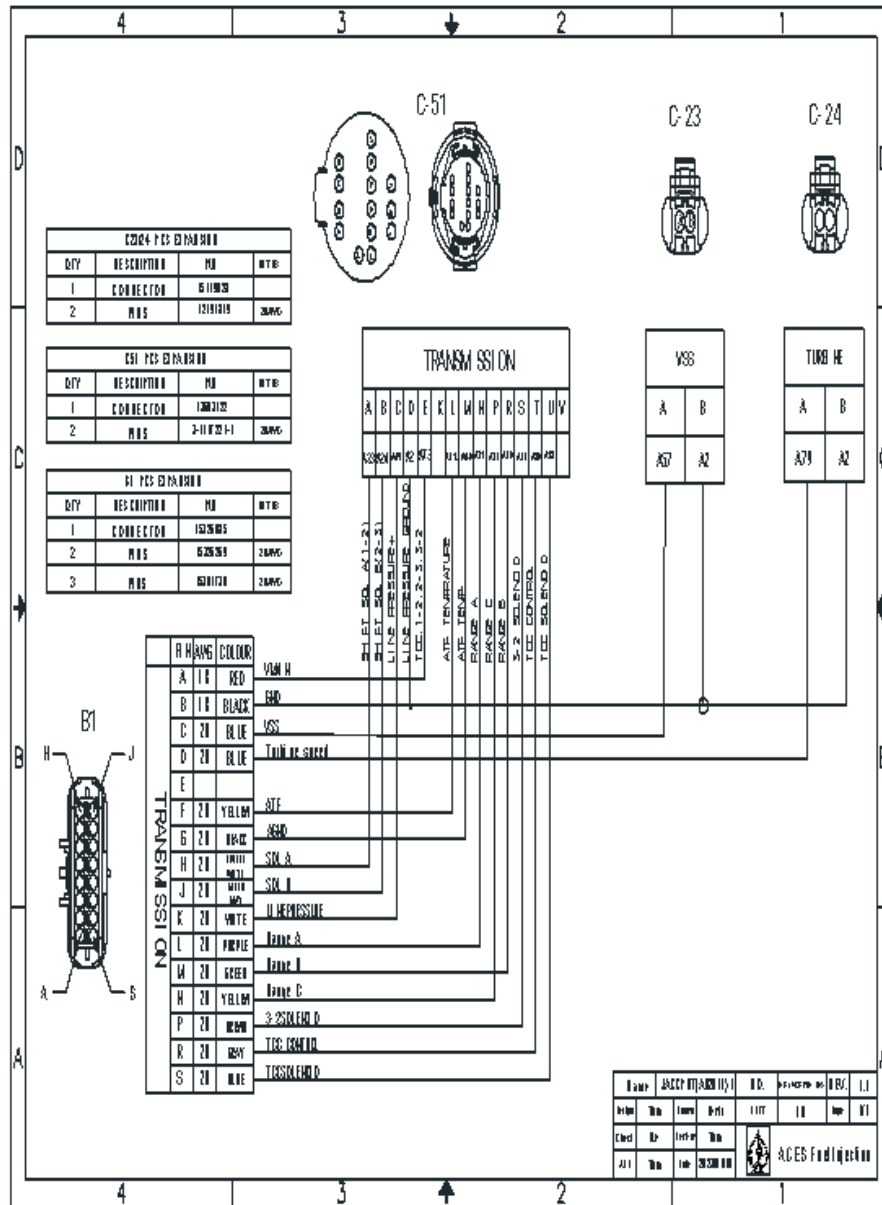

Name	Quick Draw(AH2020)-1	NO.	AC 013 Item 002	REV.	1.1
Design	Tom	Drawn	Kevin	UNIT	IN
Check	He	Review	Tom	Page	1/1
APR	Tom	Date	2023/12/20	 ACES Fuel Injection	

4L60/65 4L80/85 Trans sub harness AH2011-1

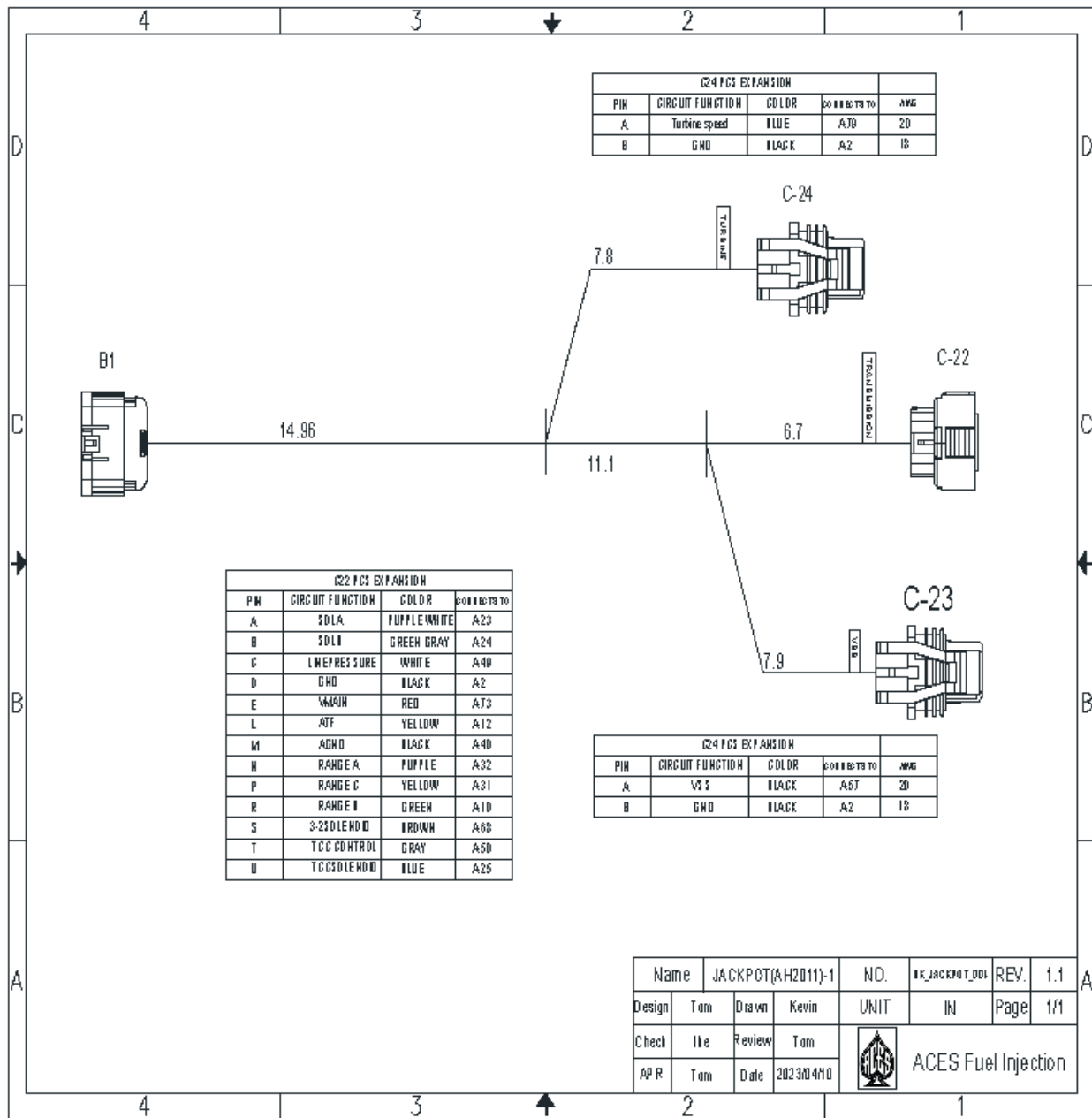



Name	JACKPOT(AH2011)-1	NO.	AK_JACKPOT_001	REV.	1.1
Design	Tom	Drawn	Kevin	UNIT	IN
Check	Ike	Review	Tom	Page	1/1
APR	Tom	Date	20230410	 ACES Fuel Injection	

VSS extension harness AH2020-2

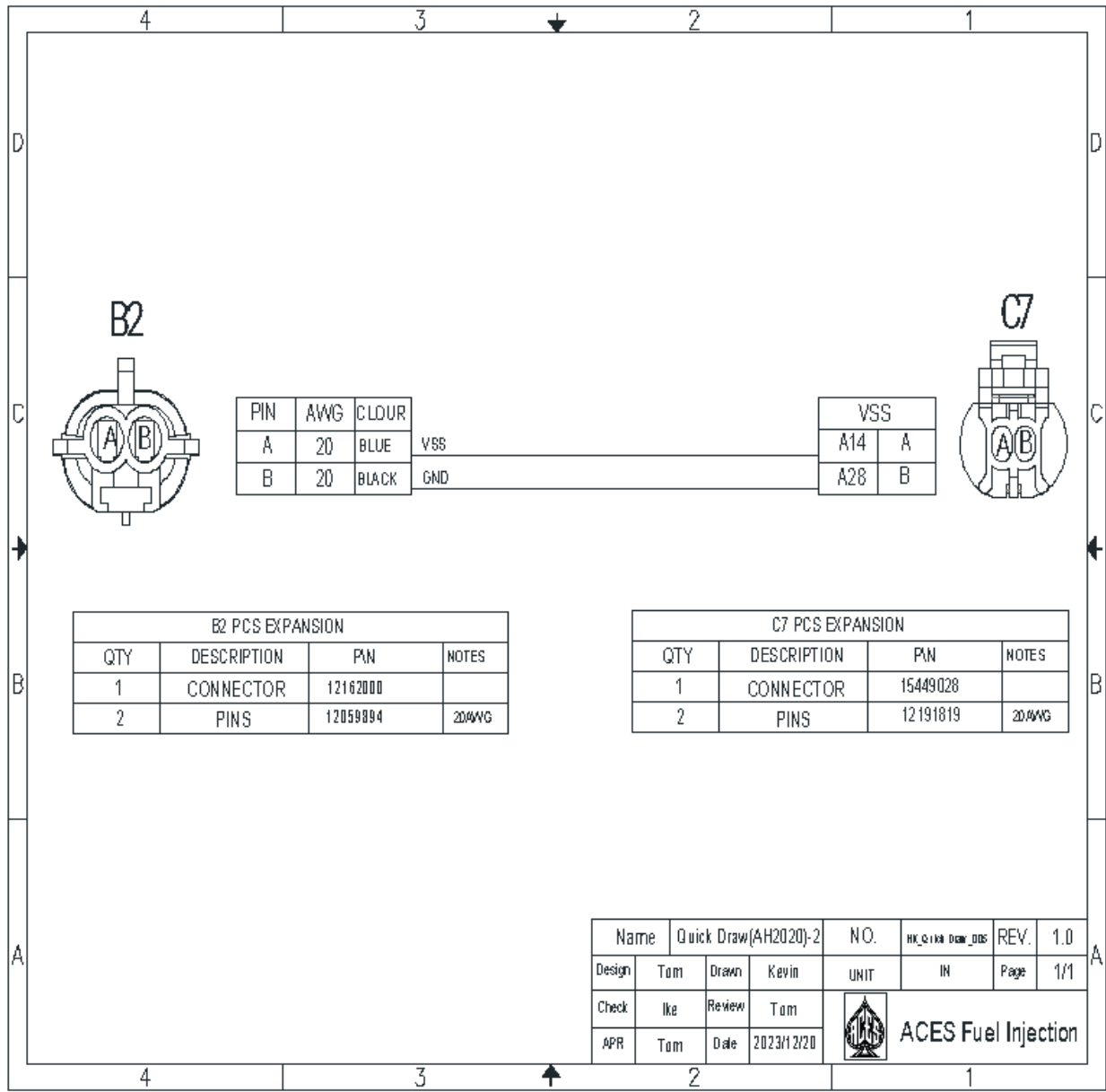

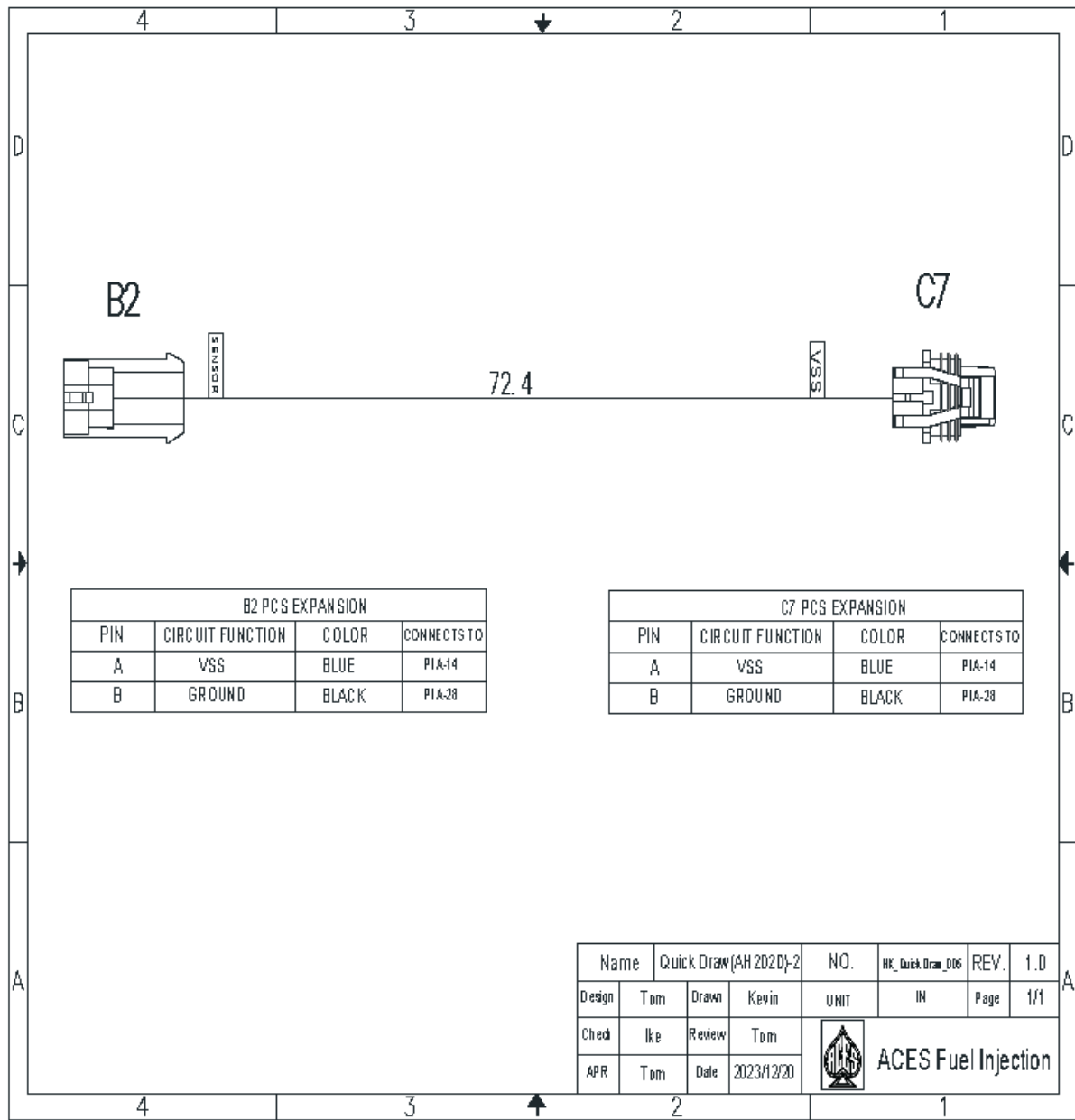

B2 PCS EXPANSION			
PIN	CIRCUIT FUNCTION	COLOR	CONNECTS TO
A	VSS	BLUE	PIA-14
B	GROUND	BLACK	PIA-28

C7 PCS EXPANSION			
PIN	CIRCUIT FUNCTION	COLOR	CONNECTS TO
A	VSS	BLUE	PIA-14
B	GROUND	BLACK	PIA-28

Name		Quick Draw (AH 2020)-2		NO.	HK_Quick Draw_006	REV.	1.0
Design	Tom	Drawn	Kevin	UNIT	IN	Page	1/1
Check	Ike	Review	Tom	 ACES Fuel Injection			
APR	Tom	Date	2023/12/20				

Additional wires AH2020-3

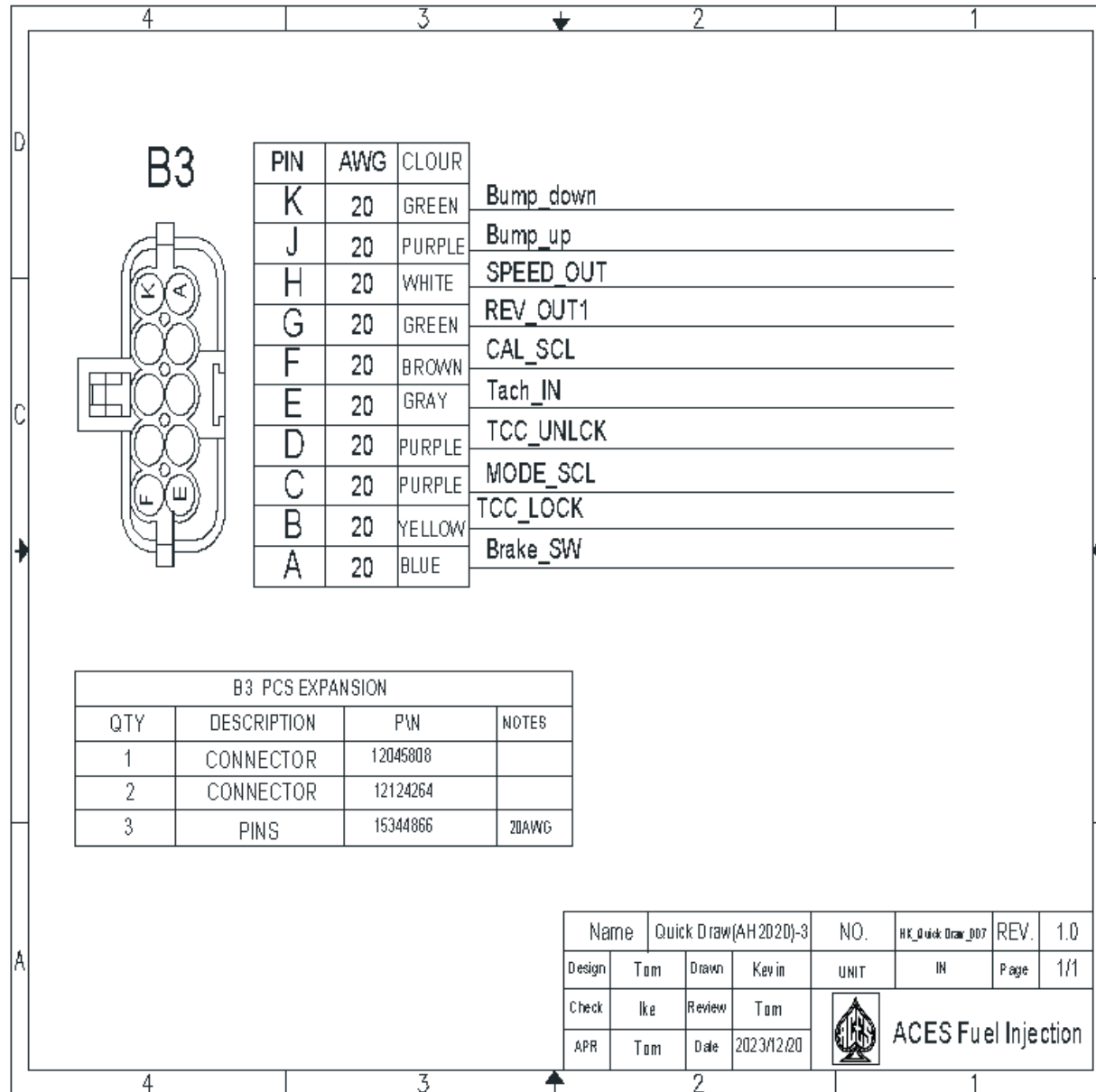

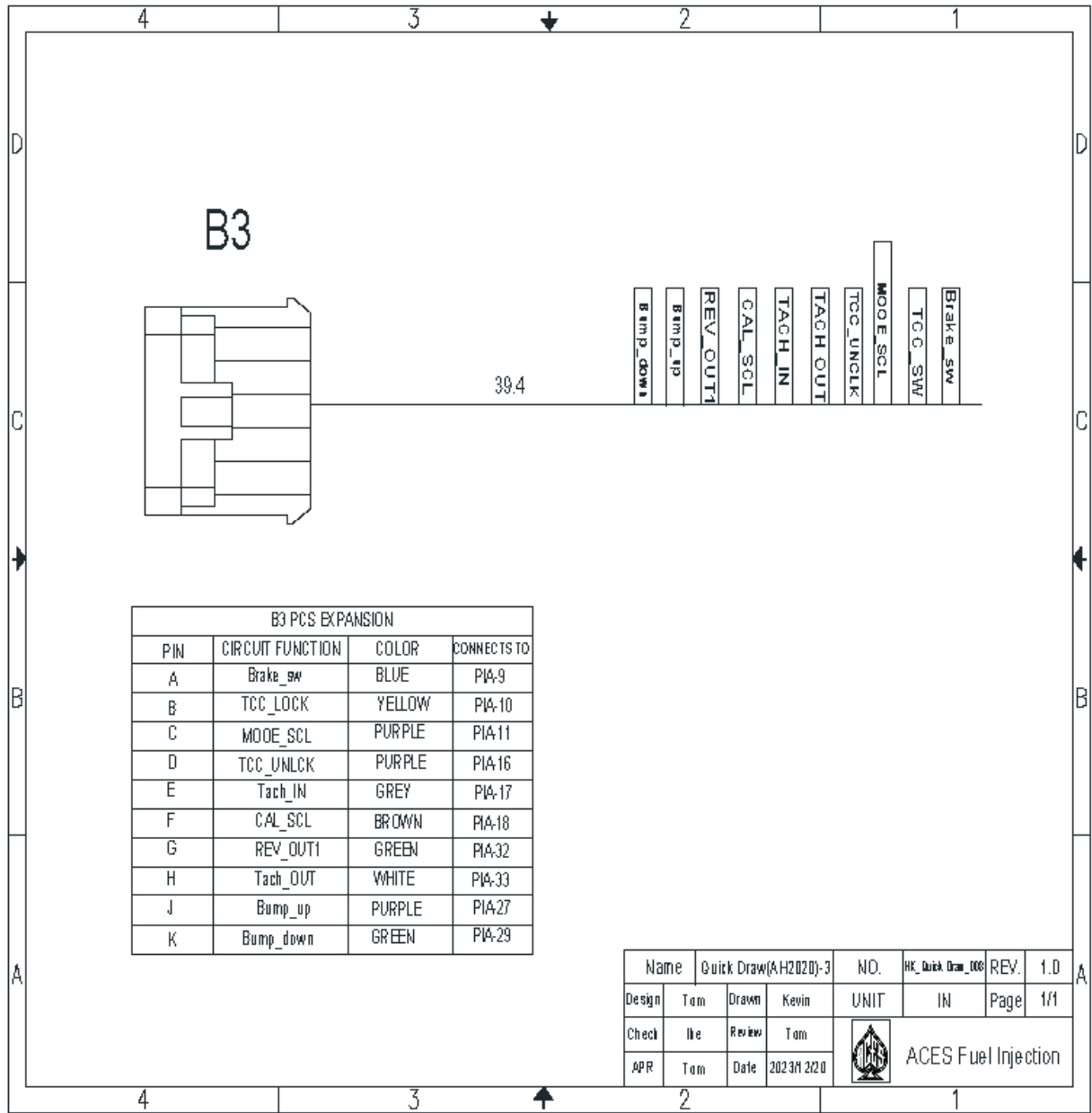

B3 PCS EXPANSION			
PIN	CIRCUIT FUNCTION	COLOR	CONNECTS TO
A	Brake_sw	BLUE	PIA-9
B	TCC_LOCK	YELLOW	PIA-10
C	MODE_SCL	PURPLE	PIA-11
D	TCC_UNLCK	PURPLE	PIA-16
E	Tach_IN	GREY	PIA-17
F	CAL_SCL	BROWN	PIA-18
G	REV_OUT1	GREEN	PIA-32
H	Tach_OUT	WHITE	PIA-33
J	Bump_up	PURPLE	PIA-27
K	Bump_down	GREEN	PIA-29

Name	Quick Draw(AH2020)-3		NO.	HK_Quick Draw_008	REV.	1.0
Design	Tom	Drawn	Kevin	UNIT	IN	Page 1/1
Check	He	Review	Tom	 ACES Fuel Injection		
APR	Tom	Date	2023M 2020			

Aces CAN splitter cable AH2020-4

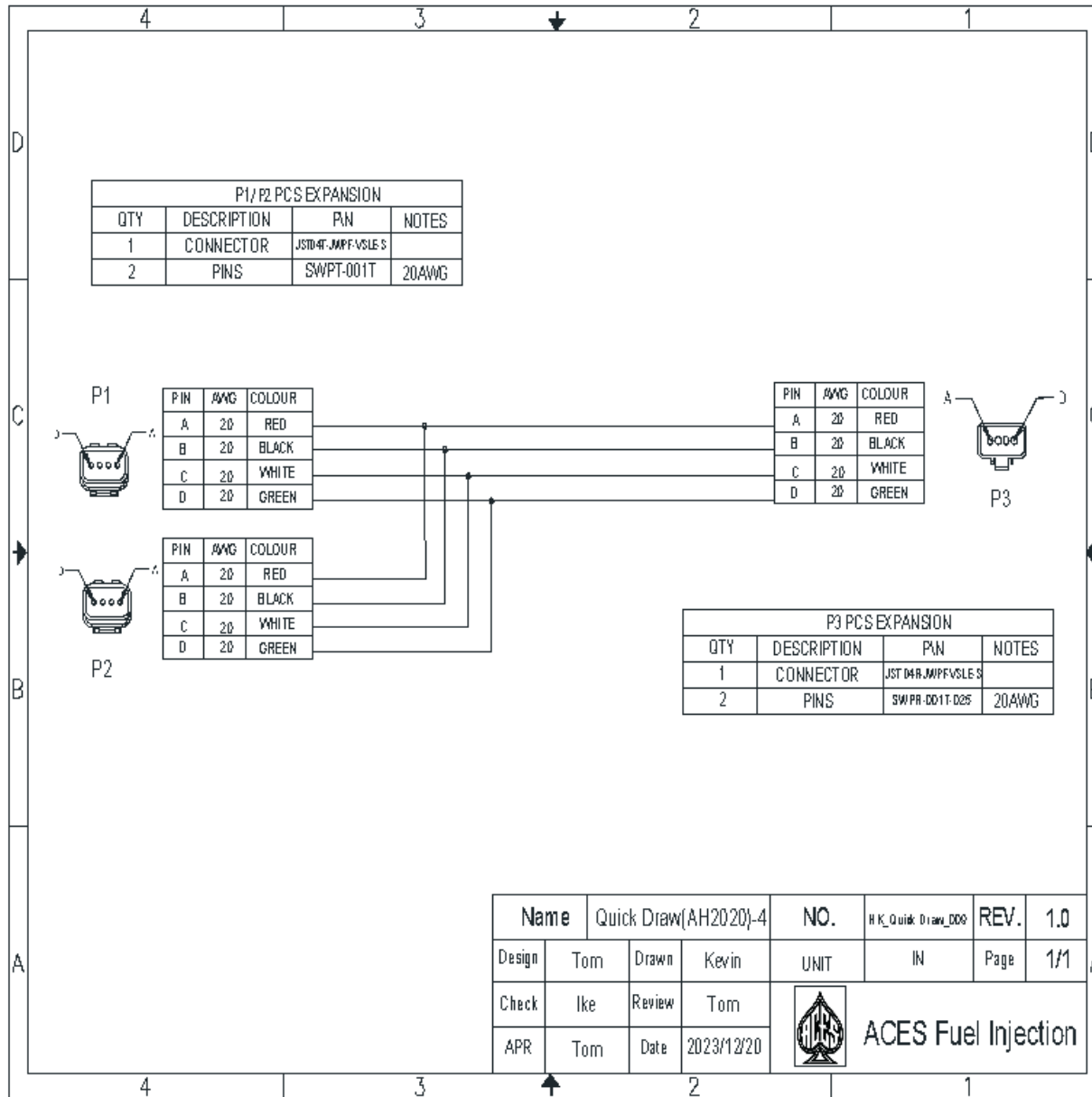

ACES FUEL INJECTION TECHNICAL SUPPORT

10188 Dayton Pike

Soddy-Daisy, TN 37379

(423) 590-2237

www.acesefi.com